

Bench

SIT/STAND, MOTOR-OPERATED, 1 SHARED TABLE SCREEN

Bench is an electrically height-adjustable desk system in modules of two workstations. The desks form a system solution with associated linking beams and cable ducts that can be connected to adjacent desks. The system makes office planning faster and more manageable, while also supporting easy scaling and expansion over time. The power supply to all workstations is also simplified, as one desk can be connected to adjacent clusters. The airy and clean design of the frames creates a consistent aesthetic expression in open and dynamic work environments and contributes to a structured and easy-to-maintain workspace.

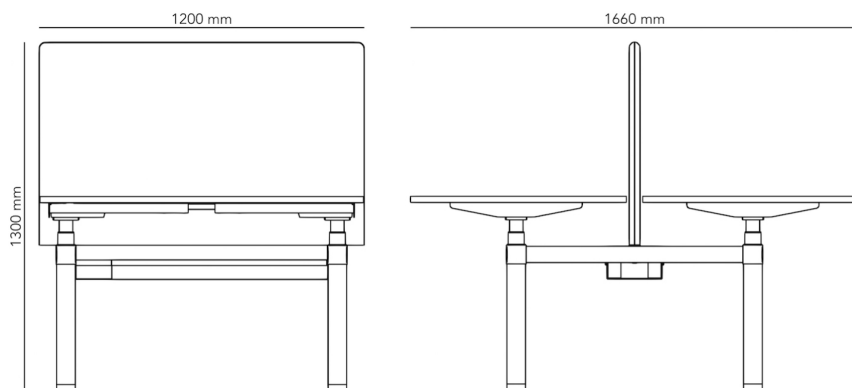

MODEL

Desk sit/stand, 2 workstations

VARIANTS

- Two workstations
- Two workstations, shared screen
- Two workstations, individual table screens

ACCESSORIES

- Table screen
- Power and cable management
- Linking cable duct
- Standing mat

DETAILS

– Motorised height-adjustable desk, one motor in each leg. The frames are raised and lowered continuously and independently of each other. Predefined desk sizes: 1200 × 800 mm, 1400 × 800 mm and 1600 × 800 mm. Square legs with the thicker section of the leg facing downwards. Straight leg ends without T-foot, with adjustable feet for levelling on the floor. Telescopic cable duct with lid for power cables, as well as cable trays for electrical accessories are included. Stroke length 650 mm. 160 kg lifting capacity (80 kg per table top), evenly distributed weight.

Bench is available in three versions: without table screen, with one shared/fixed table screen, or with two individual screens. For Bench without screens, a screen solution with one shared screen or two individual screens can be ordered separately. The shared screen has concealed fittings. Bench with one shared screen can be reconfigured into two individual screens and vice versa.

Cable duct for linking multiple workstations, concealing cable connections between desks, is available as an accessory. All versions of Bench can be converted into two individual desks if needed.

CONSTRUCTION	Motorised metal frame in powder-coated steel with rectangular legs and a straight metal foot, with plastic adjustable feet. Continuously adjustable frame rails in steel profile, adjustable within the range 1200–1600 mm. Telescopic cable duct with lid, and cable duct for linking in laser-cut, powder-coated steel, same colour as the legs. Material in cable tray: 0.7 mm sheet steel; brackets in 2 mm sheet steel. Table screen height: 730 mm.	
DIMENSIONS	Height: 1300 mm Width: 1660 mm	Length: 1200 mm Maximum load: 160 kg
WEIGHT	123.2 kg	
TESTED	EN 527-1-2, EN 1730	
WARRANTY	5 years	

Bench

SIT/STAND, MOTOR-OPERATED, 1 SHARED TABLE SCREEN

Bench is an electrically height-adjustable desk system in modules of two workstations. The desks form a system solution with associated linking beams and cable ducts that can be connected to adjacent desks. The system makes office planning faster and more manageable, while also supporting easy scaling and expansion over time. The power supply to all workstations is also simplified, as one desk can be connected to adjacent clusters. The airy and clean design of the frames creates a consistent aesthetic expression in open and dynamic work environments and contributes to a structured and easy-to-maintain workspace.

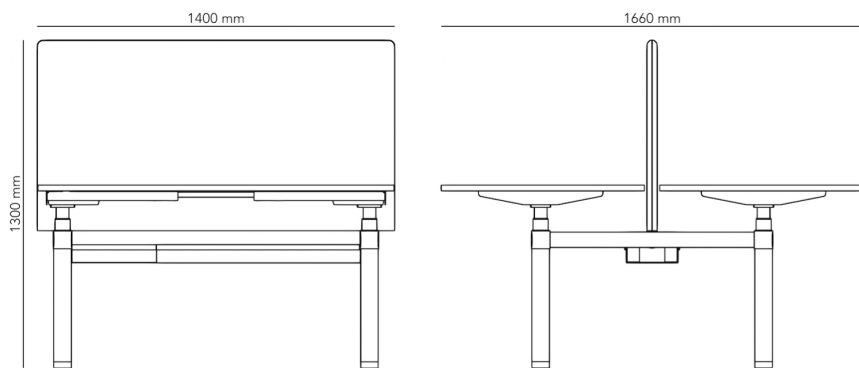

MODEL

Desk sit/stand, 2 workstations

VARIANTS

- Two workstations
- Two workstations, shared screen
- Two workstations, individual table screens

ACCESSORIES

- Table screen
- Power and cable management
- Linking cable duct
- Standing mat

DETAILS

– Motorised height-adjustable desk, one motor in each leg. The frames are raised and lowered continuously and independently of each other. Predefined desk sizes: 1200 × 800 mm, 1400 × 800 mm and 1600 × 800 mm. Square legs with the thicker section of the leg facing downwards. Straight leg ends without T-foot, with adjustable feet for levelling on the floor. Telescopic cable duct with lid for power cables, as well as cable trays for electrical accessories are included. Stroke length 650 mm. 160 kg lifting capacity (80 kg per table top), evenly distributed weight.

Bench is available in three versions: without table screen, with one shared/fixed table screen, or with two individual screens. For Bench without screens, a screen solution with one shared screen or two individual screens can be ordered separately. The shared screen has concealed fittings. Bench with one shared screen can be reconfigured into two individual screens and vice versa.

Cable duct for linking multiple workstations, concealing cable connections between desks, is available as an accessory. All versions of Bench can be converted into two individual desks if needed.

CONSTRUCTION	Motorised metal frame in powder-coated steel with rectangular legs and a straight metal foot, with plastic adjustable feet. Continuously adjustable frame rails in steel profile, adjustable within the range 1200–1600 mm. Telescopic cable duct with lid, and cable duct for linking in laser-cut, powder-coated steel, same colour as the legs. Material in cable tray: 0.7 mm sheet steel; brackets in 2 mm sheet steel. Table screen height: 730 mm.	
DIMENSIONS	Height: 1300 mm Width: 1660 mm	Length: 1400 mm Maximum load: 160 kg
WEIGHT	132.0 kg	
TESTED	EN 527-1-2, EN 1730	
WARRANTY	5 years	

Bench

SIT/STAND, MOTOR-OPERATED, 1 SHARED TABLE SCREEN

Bench is an electrically height-adjustable desk system in modules of two workstations. The desks form a system solution with associated linking beams and cable ducts that can be connected to adjacent desks. The system makes office planning faster and more manageable, while also supporting easy scaling and expansion over time. The power supply to all workstations is also simplified, as one desk can be connected to adjacent clusters. The airy and clean design of the frames creates a consistent aesthetic expression in open and dynamic work environments and contributes to a structured and easy-to-maintain workspace.

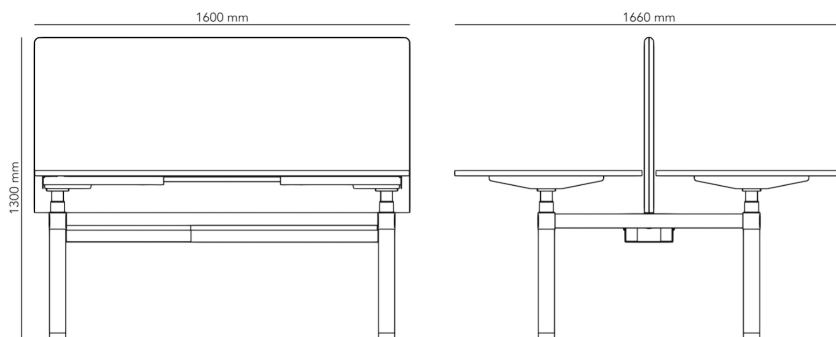

MODEL

Desk sit/stand, 2 workstations

VARIANTS

- Two workstations
- Two workstations, shared screen
- Two workstations, individual table screens

ACCESSORIES

- Table screen
- Power and cable management
- Linking cable duct
- Standing mat

DETAILS

– Motorised height-adjustable desk, one motor in each leg. The frames are raised and lowered continuously and independently of each other. Predefined desk sizes: 1200 × 800 mm, 1400 × 800 mm and 1600 × 800 mm. Square legs with the thicker section of the leg facing downwards. Straight leg ends without T-foot, with adjustable feet for levelling on the floor. Telescopic cable duct with lid for power cables, as well as cable trays for electrical accessories are included. Stroke length 650 mm. 160 kg lifting capacity (80 kg per table top), evenly distributed weight.

Bench is available in three versions: without table screen, with one shared/fixed table screen, or with two individual screens. For Bench without screens, a screen solution with one shared screen or two individual screens can be ordered separately. The shared screen has concealed fittings. Bench with one shared screen can be reconfigured into two individual screens and vice versa.

Cable duct for linking multiple workstations, concealing cable connections between desks, is available as an accessory. All versions of Bench can be converted into two individual desks if needed.

CONSTRUCTION	Motorised metal frame in powder-coated steel with rectangular legs and a straight metal foot, with plastic adjustable feet. Continuously adjustable frame rails in steel profile, adjustable within the range 1200–1600 mm. Telescopic cable duct with lid, and cable duct for linking in laser-cut, powder-coated steel, same colour as the legs. Material in cable tray: 0.7 mm sheet steel; brackets in 2 mm sheet steel. Table screen height: 730 mm.	
DIMENSIONS	Height: 1300 mm Width: 1660 mm	Length: 1600 mm Maximum load: 160 kg
WEIGHT	139.7 kg	
TESTED	EN 527-1-2, EN 1730	
WARRANTY	5 years	